

## Trouble Shooting Guide

### Pump

System Problem	Possible Problem	Solutions
The motor does not start.	Fuse or thermal relay disconnected.	Change fuse or thermal relay.
The motor does start. Motor starts and stops continuously.	Pump blocked.	Disconnect it and take it to Dealer.
	Wrong voltage.	Check that the tension is the same as that on the voltage motor rating plate.
Flow is insufficient	Foot valve clogged.	Clean it or replace by new one.
	Venturi clogged.	Disassemble and take it to your Dealer.
There is no suction. Flow is insufficient.	Total manometric head higher than expected.	Verify manometric head and loss of head in pipe work.
There is no suction. Motor runs but it gives no pressure. Flow is insufficient.	Water level in well or tank is too low.	Verify suction head for normal operation. Consider repositioning the pump to a low level.
There is no suction. Motor runs but it gives no pressure.	Foot valve not submerged.	Be sure suction pipe is submerged.
	Pump was not primed.	Fill pump body with water.
	Air entry.	Seal unions and joints properly.
Motor runs but it gives no pressure. Flow is insufficient.	Impellers are worn out.	Disconnect pump and take it to your Service Dealer.
Motor over-heating. Motor starts and stops continuously.	Room not properly ventilated.	Provide good ventilation.

### Controller

System Problem	Cause on the Unit	Cause not depending on unit
The pump does not start.	The electronic card is broken.	Voltage failure. Pump jammed. Electric cables inverted (Line/ motor).
The pump does not stop when taps are closed.	The electronic card is broken. The flow detector is locked in the upper position. The reset button is locked. The pump does not provide sufficient pressure.	Presence of leaks in systems which are higher than the minimum flow 0.6 l/min.
Intermittent pump working.	The electronic card is broken. The pump does not provide sufficient pressure.	Presence of leaks in systems which are higher than the minimum flow 0.6 l/min.
The pump is jammed.	The electronic card is broken. The pump provides a pressure which is lower than the restart pressure.	Water failure. Suction problems.

For more technical support contact your local dealer.

Rotaflow Pumps are marketed and sold by



**vanglobe**  
specialising in compounding & micronising  
[www.vanglobegroup.com](http://www.vanglobegroup.com)  
Made in China

Your Local Dealer is



## Rotaflow V100 Water Pump and Controller Set Installation and Operating Manual

Pump Model	Power kW	Speed rpm	Connections		Constructions	
			Inlet	Outlet	Casing	Impeller
V100	0.75	2900	1" BSP	1" BSP	St. Steel	Dupont Zytec®
Flow (L/min)	10	20	30	40	50	60
Head (m)	40	36	32	28	24	21

The Rotaflow V100 Water Pumps are a quality, economic pump used to transfer water from rainwater tanks and bores. The model V100 Jet Pump is a stainless steel cased horizontal self priming centrifugal electric pump unit.

The pump has been designed to handle clean liquid not containing any solid particles. The liquid must not exceed a maximum temperature of 45°C. The pump is suitable for both suction lift and flooded suction applications.

### Usage

**Capacity** 5 Taps

**Pressure** Ideal for single storey houses

### Performance Curve

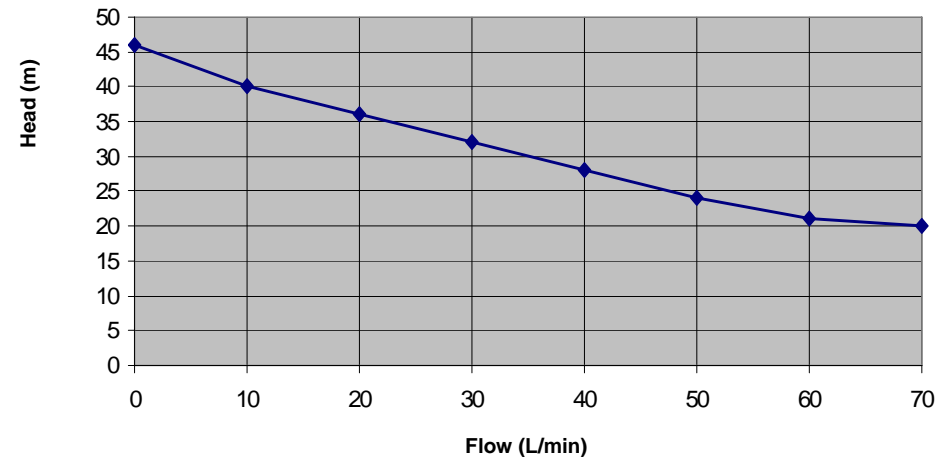

### Maintenance

Our electro pumps do not need any special maintenance, but should be placed in a clean dry location. It is important to periodically check the pipe connections for possible leaks. Pump body should be drained during periods of low temperatures or long period of inactivity. If this inactivity lasts longer than 6 months, pump should be cleaned and kept in a dry and well aired place.

## Wiring Diagram

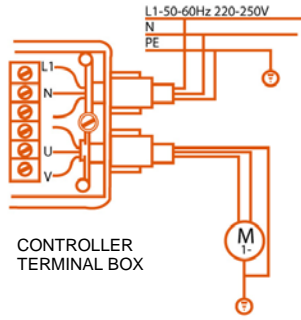

CONTROLLER  
TERMINAL BOX

Wiring diagram for connection of single-phase 220V pumps up to 1.1Kw.

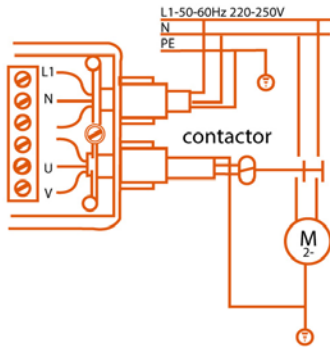

Wiring diagram for connection of single-phase 220V pumps over 1.1Kw, through remote control switch.

**Specifications for remote control switch.** Minimum contacts capacity of 4Kw or 5.5 HP approx. 220V.

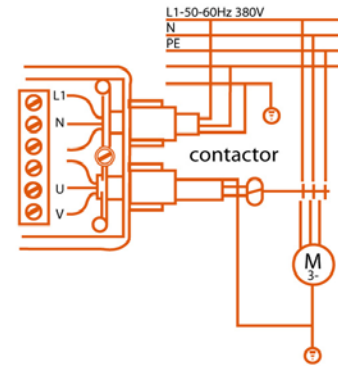

Wiring diagram for connection of three phase 380V motor pups through remote control switch.

**Specifications for remote control switch.** Minimum contacts capacity of 4Kw or 5.5 HP approx. 220V.

**Any alteration to the electrical wiring of the pump and controller should only be done by a qualified electrician.** Since it is likely the pump will be coupled to a plastic pipe, the motor casing should be well earthed. A 3-pin plug should be fitted but an additional earth connection from motor feet to earth is also advisable.

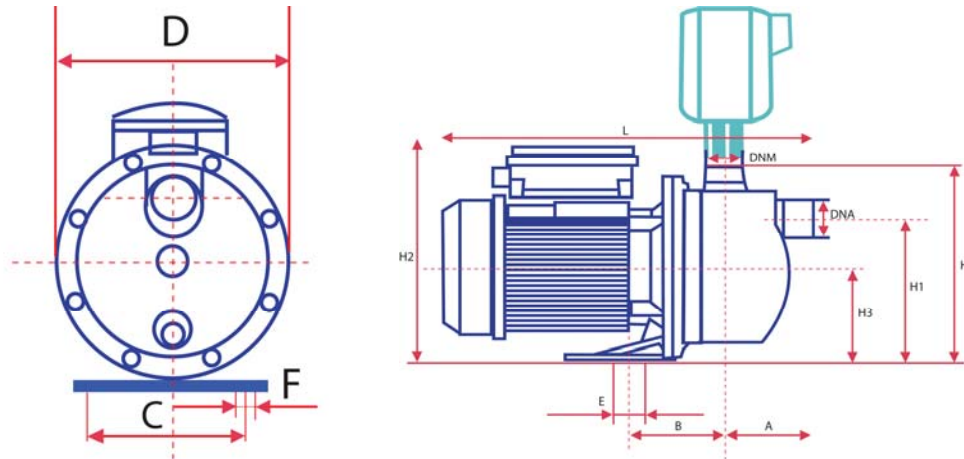

## Overall Dimensions (mm)

Model	A	B	C	D	E	F	H	H1	H2	H3	J	DNA	DNM	Weight (KG)
V100	80	80	98	184	20	10	203	157.5	202	98	354	G1	G1	9.0

Total Pump and Controller Height

357mm

## Installation

Failure to observe these precautions involves a risk of damaging the pump and/ or the plan. When fitted as part of a water tank installation the pump has a flooded suction (supply from tank). For shallow well applications (suction lift) the pump has a maximum suction capability of 7m. A good quality foot valve must be installed.

The pump should be mounted on a firm foundation, in a horizontal position and as close as possible to the water tank, in order to optimum performance. The pump location should be dry and safe from any possible flooding.

The suction pipe must be a not collapsible type. All pipes must be installed and supported correctly to ensure the pump casing is not strained by weight or misalignment. All pipe joints should be sealed and leak free.

**The pump must be primed prior to initial start up.** For flooded suction (supply from tank) ensure suction valve is fully open and water flows freely to the pump inlet connection. For shallow well (suction lift), remove priming plug, fill pump and suction pipe with water – ensuring water level does not drop – replace plug and start pump.

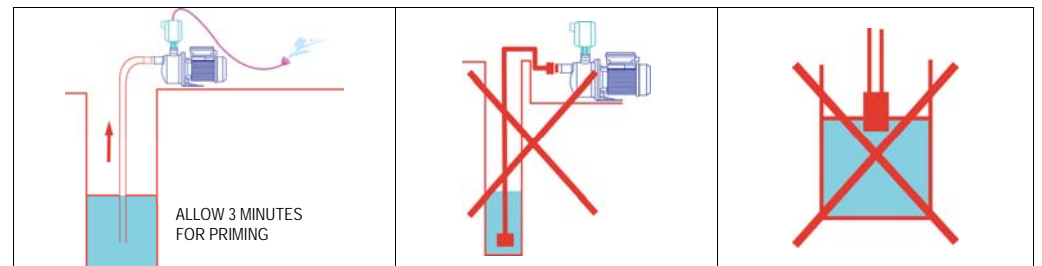
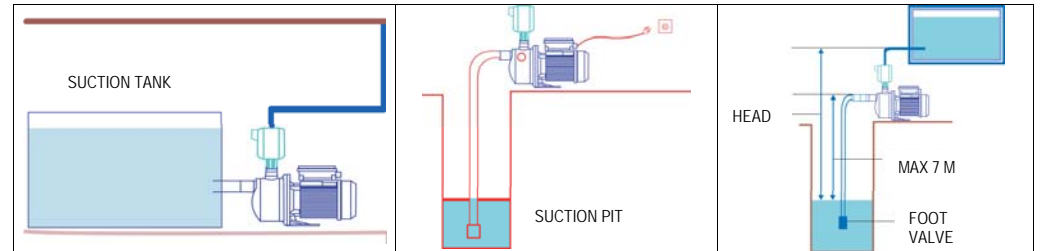
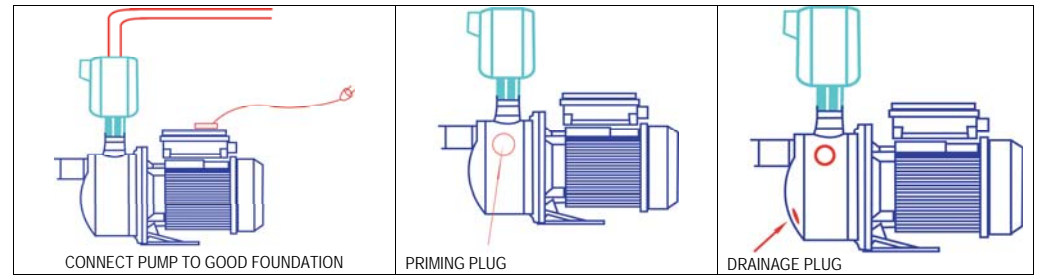

## Starting

Open all gate valves installed in the suction and connect the electric supply switch. Wait for the priming to be completed. If a foot valve has been installed, the priming will occur directly after the initial priming. If motor fails to start or does not deliver water please refer to *Trouble Shooting* list for the possible problems and consequent actions to take. This information will be found on the back page of the brochure.